

NOTE:
DIMENSIONS INDICATED ARE
DEPENDENT ON BASIS-OF-DESIGN
DISPLAY CASE MANUFACTURER
FIXTURE SIZES AND REQUIRED
CLEARANCES. IF COMPARABLE
PRODUCTS FROM ANOTHER
MANUFACTURER ARE PROVIDED,
ADJUST DIMENSIONS
ACCORDINGLY. CASEWORK PLAN
CONFIGURATION MAY VARY FROM
THAT SHOWN IN THIS DESIGN
STANDARD PLATE - CONFIGURATION
SHALL BE AS INDICATED ON
EQUIPMENT FLOOR PLAN.

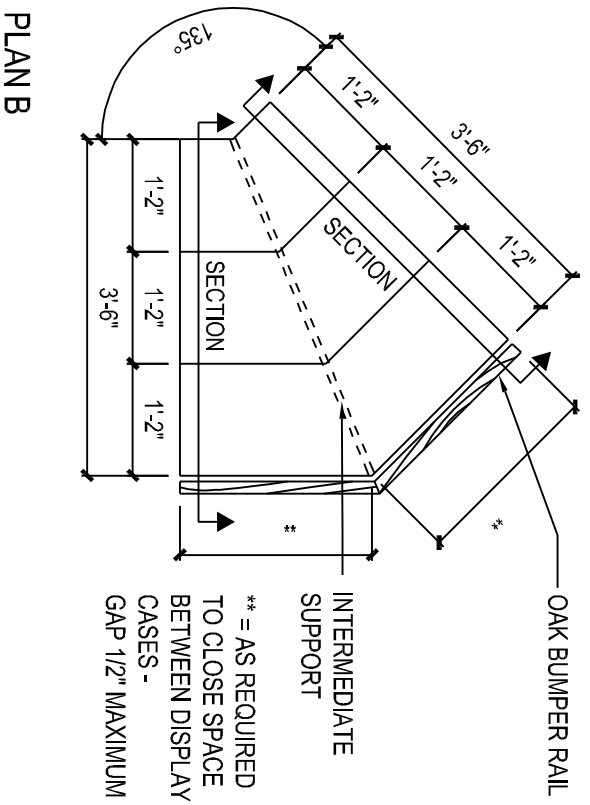

STEPPED CASEWORK DETAIL (DELI/BAKERY)

| | | | |
|----------|---|----------------------------|--------------------|
| DATE | DEFENSE COMMISSARY AGENCY DIRECTORATE OF ENGINEERING FORT LEE, VIRGINIA - LACKLAND AFB, TEXAS | | DESIGN STANDARD |
| JUN 2022 | TITLE | DEL/BAKERY STEPPED DISPLAY | 064023-03 |
| | REF. | | |
| | REV. | | |